

# INSTALLATION INSTRUCTIONS FOR ELECTRIC HEATED HIGH VELOCITY AND EXTRA POWER MODELS

## READ INSTRUCTIONS BEFORE REMOVING FROM CARTON

### SAVE THIS SHEET FOR FUTURE REFERENCE

#### PRELIMINARY

1. Before removing the unit from the carton, unscrew the plastic nuts and remove the adjustable velocity control louver.
2. Remove the Motor/Fan Assembly from its carton. Industrial models have the motor/fan assembly(s) shipped separately. Be careful not to touch the dynamically balanced wheels or damage the electric heating elements when removing the motor/fan assembly from the box.
3. Remove the housing from the carton.

**WARNING: TO REDUCE THE RISK OF FIRE, ELECTRIC SHOCK OR INJURY TO PERSONS, OBSERVE THE FOLLOWING:**

- A. Installation work or electrical wiring must be done by qualified person(s) in accordance with all applicable codes and standards, including fire-rated construction.
- B. The combustion airflow needed for safe operation of fuel burning equipment in the area may be affected by the unit's operation. Follow the heating equipment manufacturer's guideline and safety standards, such as those published by the National Fire Protection Association (NFPA), the American Society of Heating, Refrigeration and Air Conditioning Engineers (ASHRAE) and local code authorities.
- C. When cutting or drilling into a wall or ceiling, be careful not to damage electrical wiring and other hidden utilities.

FIGURE 1

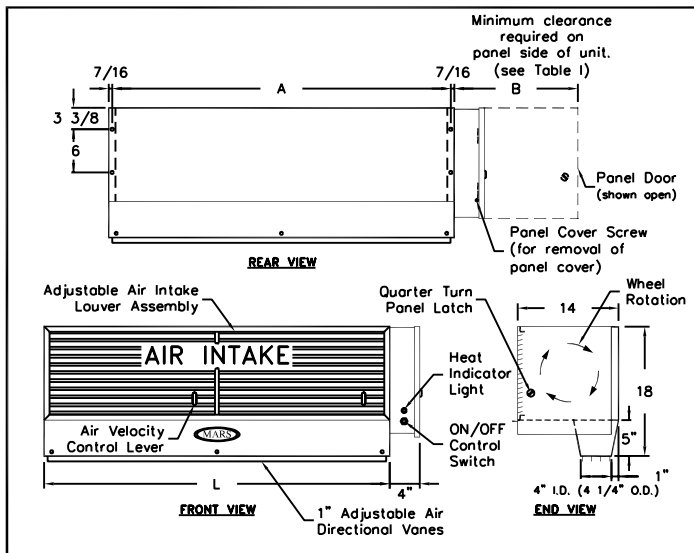
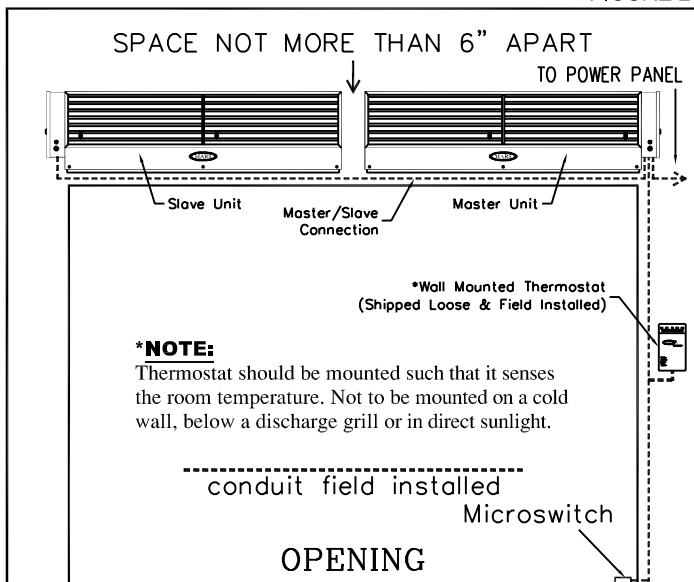

FIGURE 2



#### TO INSTALL HOUSING AND MOTOR/FAN ASSEMBLY

1. Measure the housing, and then center it on the wall over the doorway opening. See Table I for the minimum clearance required on the panel side of the unit for access and service.
2. Spot holes through 7/16" mounting holes. (2) on each end of the housing. If necessary, drill extra holes in the back of the housing to align with stud spacing. (see Figure 1)
3. Mount the unit with the discharge nozzle 1" above the door opening. If the unit is mounted higher, move it 3/8" away from the wall for every 1" it is moved up above the door. Any void between wall and unit must be sealed for optimum performance. Rods may be used for overhead installation.
4. Use all four mounting holes when installing the housing.
5. When mounting multiple units side by side, allow no more than 6" between the units. Master/Slave configuration required to allow the units to operate simultaneously. (Single T'stat Control) (see Figure 2)
6. Replace Motor/Fan Assembly(s) in the housing and secure with wingnuts. Connect all motor(s) and electric heater(s) connections.
7. Replace the intake louver or inlet screen and fasten with the hex nuts.
8. Connect panel to proper voltage. Check the motor rotation. (see Figure 1)

#### ADJUSTMENTS

1. Pull air directional vanes in air discharge nozzle to proper position with air flow slanted slightly outward around 15°.
2. Set air velocity control louvers so that the air stream just reaches the floor to prevent turbulent mixing of inside and outside air.
3. The unit is to be installed such that the airflow is unobstructed.
4. The thermostat should be mounted such that it senses the room temperature. Do not mount thermostat on a cold wall, below a discharge grill or in direct sunlight. The high limit switches may trip, shutting off the heat, if improperly installed.

**NOTE: MODEL NUMBER DESIGNATES THE LENGTH OF THE UNIT IN INCHES, WHICH IS DENOTED AS "L". ALL DIMENSIONS ARE IN INCHES.**

TABLE I

MODEL NUMBER	MOTOR HP	NUMBER OF MOTORS	MOUNTING CENTER (A)	MIN. PANEL CLEARANCE REQ'D (B)
E48HV	1	1	47 1/8	17"
E60HV	1	1	59 1/8	17"
E72HV-2	1	2	71 1/8	21"
E84HV-2	1	2	83 1/8	21"
E96HV-2	1	2	95 1/8	21"
E120HV-2	1	2	119 1/8	21"
E120HV-3	1	3	119 1/8	21"
E144HV-3	1	3	143 1/8	21"
EEP48	3	1	47 1/8	17"
EEP60	3	1	59 1/8	17"
EEP72-2	3	2	71 1/8	21"
EEP84-2	3	2	83 1/8	21"
EEP96-2	3	2	95 1/8	21"
EEP120-2	3	2	119 1/8	21"
EEP120-3	3	3	119 1/8	21"
EEP144-3	3	3	143 1/8	21"

#### CONTROL PANEL INSTALLATION

- A. Connect supply voltage from power panel to control panel. Circuit protection as per NEC by others.
- B. Connect motor and heater leads to leads from the control panel and connect thermostat to terminals in panel per print.
- C. Connect wires from microswitch to terminals in control panel per print.
- D. Re-check rotation of blower wheels. Switch leads if necessary to correct.
- E. The door microswitch has normally closed contacts. The contacts open when the door shuts depressing the plunger, turning the blowers off.

# MAINTENANCE INSTRUCTION

**WARNING: TO REDUCE THE RISK OF FIRE, ELECTRIC SHOCK OR INJURY TO PERSONS, OBSERVE THE FOLLOWING:**

- A. Use this unit only in the manner intended by the manufacturer. If you have questions, contact the manufacturer.
- B. Before servicing or cleaning the unit, switch power off at service panel and lock service panel to prevent power from being switched "ON" accidentally.
- C. To reduce the risk of electric shock, DO NOT use this fan with any solid state speed control device.

## PRELIMINARY

It is imperative to keep the fans clean. Failure to do so may cause excess buildup of residue. This will lower efficiency and eventually throw fans out of balance, which can shorten the life of the blower wheels and cause undue wear on the bearings. The time between cleaning depends upon the type and amount of particles floating

in the air. Under normal circumstances, the system will only require cleaning approximately once a year.

Clean motors and fans when necessary for peak operational efficiency. Motor-fan assembly may be easily cleaned by removing it from the housing. Remove the Motor/Fan Assembly from the housing by disconnecting all electrical connections from the motor to the panel, then removing the two wing nuts on either side of the pan. Be careful not to touch the blower wheels and the heating elements.

Occasionally remove the velocity control louvers and wash with soap and water. At the same time, it is advisable to wipe any accumulation of dirt off the motor.

**No lubrication is necessary as all motors have lifetime prelubricated, double sealed ball bearings. Motor contains automatic thermal overload protection as standard.**

## ALL PARTS ARE FOB OUR FACTORY - GARDENA, CA

1 or 3 in part numbers below designates motor horse power in air curtain. When ordering parts, include the serial and model number from the name plate of the unit. When ordering blower wheels, specify whether steel or stainless steel.

## MOTOR CHARACTERISTICS AVAILABLE (Three Phase Only)

1 HP.....1750 RPM    3 HP.....3400 RPM

## MOTOR/FAN ASSEMBLY

Complete assembly consists of a motor, blower wheel, blower housing and motor pan. Available in three phase only.

## MOTOR PAN

MP-30-1 · MP-30-3

## VELOCITY CONTROL LOUVERS · AIR CURTAIN HOUSING · DIRECTIONAL VANES

Specify model number when ordering

## BLOWER HOUSING

Universal housings are good for either side of the motor. All sizes available in Polymars® or metal.

## BLOWER WHEEL

MOTOR HP	METAL BLOWER WHEEL
1	UNIVERSAL
3	UNIVERSAL (STAINLESS ONLY)

NOTE: Universal indicates the wheel may be used on either side of the motor. Direction of wheel rotation is not required.

## ELECTRIC HEATER PARTS

Electric Heating Coil Assembly, Thermal Overload Relay, T'stat, Contactor (2 or 3 Pole, 40 or 50 Amps), Relay (2 or 3 Pole), Fuse Blocks, Fuses, Transformer, On/Off Switch, Indicator Light, Wiring Cover, Heat Shield Plate.

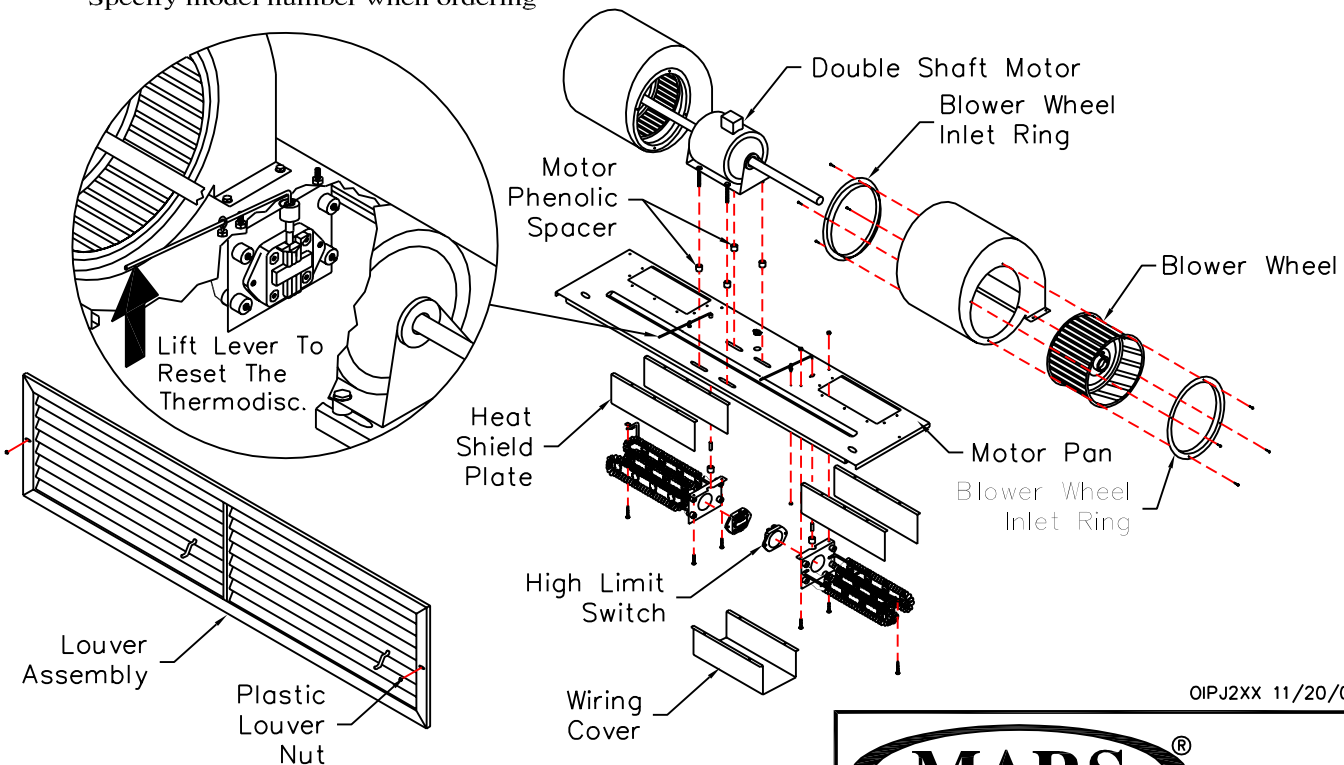

OIPJ2XX 11/20/00 FRC



*Air Doors*  
BRAND AIR CURTAIN

14716 S. BROADWAY • GARDENA, CA 90248  
Tel: (310) 532-1555 • (800) 421-1266 • Fax: (310) 324-3030  
Web Site: www.marsair.com • E-mail: marsserve@marsair.com